

# INSTALLATION INSTRUCTIONS:

## RIGHT HAND SIDE cupboard mount (PTO for L/H side mount)

Unit is factory assembled for R/H side mount.

Always read **SAFETY INSTRUCTIONS** in manual, pages 3 & 6.

### Unpack fixings & fittings inside bag compartment.

**NOTE:** Push dustpan door in to take screw caps off from inside edge.

#### 1. Use templates to mark hole & cut

The KitVac sits on the bottom shelf about 15mm from the door hinge or 80mm from back of cupboard door. Cut rear hole first & before cutting dustpan, check that you have clear access. Centre dustpan to cupboard door/s.

#### 2. Feed cable & pipe down and out through your dustpan cut out

Place fast cap around dustpan hose and cable before feeding down. You can cut hose with knife, if it's too long.

#### 3. Secure fittings with several tight layers of tape provided in the kit

Smooth adaptor to hose & then to your dustpan. 90 degree bend to other end and then to machine (ensure bend is straight before taping).

#### 4. Connect Dustpan Low voltage wires

Plugs into separate spade terminals (there is no positive or negative). Push connectors only, not by the wires. Note position of forks & check your clearance from moving spring (open/close your door).

#### 5. Secure Dustpan

Ensure flat to the floor, pre-drill holes & then screw. Use 2 x pieces of double sided tape provided to further secure dustpan caps.

#### 6. Secure Unit

Pre-drill holes & secure with 2 x screws & washers. Secure fast cap at rear by peeling away adhesive. Further secure cover plate with glue (make permanent).

#### 7. Fitting Accessories:

Secure broom handle & pole with the screw.  
To extend broom pole, just twist pole at either end in opposite directions.  
Extra long crevice tool attaches at both ends (3 x pieces in total)  
Fit hose hanger to door with screws provided  
**Ensure motor filter is in bag compartment & also fit bag**

### Dimensions:

Height 370mm

Length 280mm + Pipe

Width 180mm

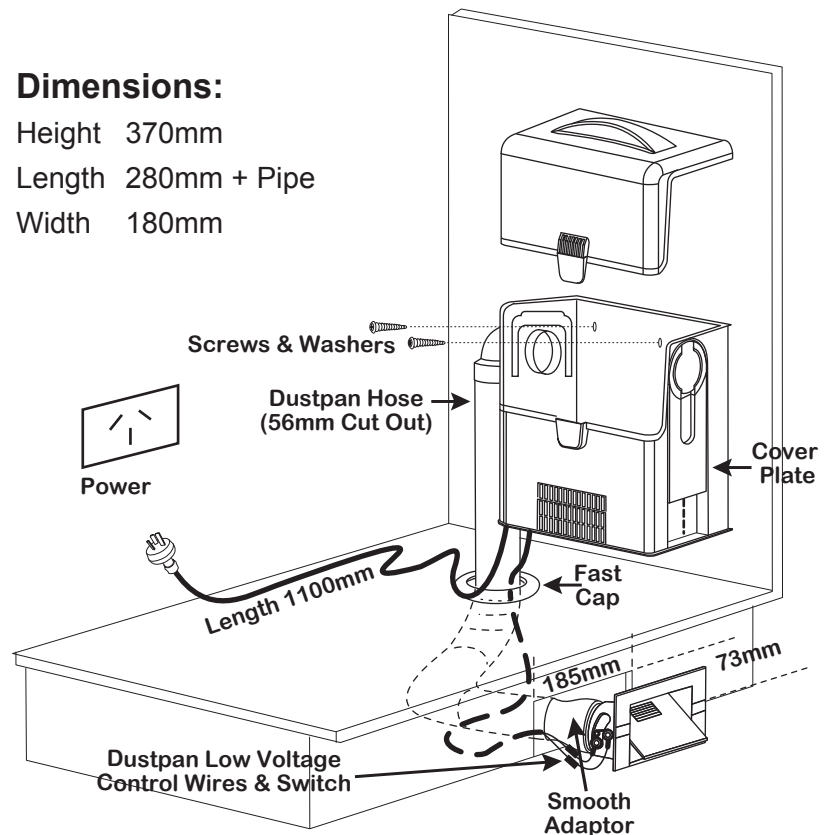

# INSTALLATION INSTRUCTIONS:

## LEFT HAND SIDE cupboard mount (PTO for R/H side mount)

It takes 5 minutes to change unit to L/H side mount.

Always read **SAFETY INSTRUCTIONS** in manual, pages 3 & 6.

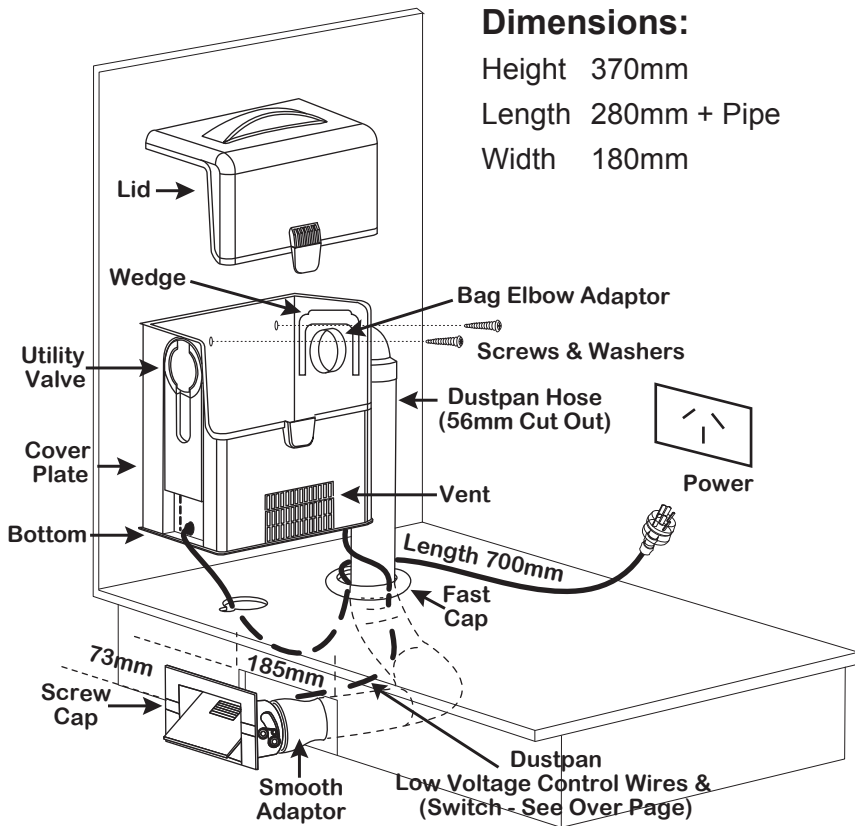

### Change Unit from R/H side to L/H side mount:

1. **SAFETY:** Always have power off and lead unplugged before removing bottom.
2. Remove lid, cover plate & 2 x wedges (inside bag compartment).
3. Turn machine upside down, remove bottom (4 x screws) & release wire tie attached to vent.
4. Now swap positions of the bag elbow adaptor with the utility valve (when pulling out follows the shape of the bend) and both sets of the low voltage wires (that's the utility valve and dustpan low voltage cables).
5. Slide out the air vent & turn 180 degrees & refit (arrow at bottom now points towards front of unit).

Wire Tie

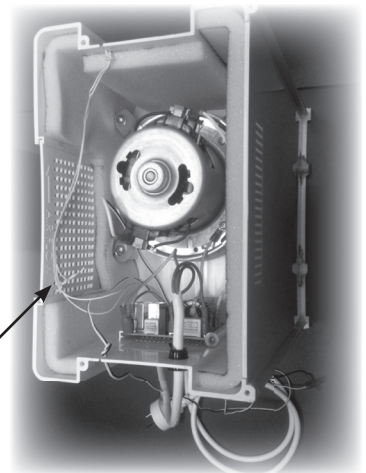

### You can now re-assemble your unit;

1. Refit wire tie to vent holding your low voltage cables.
2. Refit base with 4 x screws and turn your unit up again.
3. Refit both wedges to secure your utility valve & bag elbow adaptor.
4. Refit cover plate.

### Your Unit should now look like this & ready for L/H side installation as follows;

1. Use L/H side template to drill an extra hole & groove for the lead at the front of machine.
2. Feed your lead down first and out through your rear dustpan hose cut out.
3. Cut a groove for your lead in your fast patch. (Now refer over page for remaining steps).

